

GXCON ENTERPRISE CO., LTD

DOCUMENT NO.
SERIAL NO.
WF3960PP

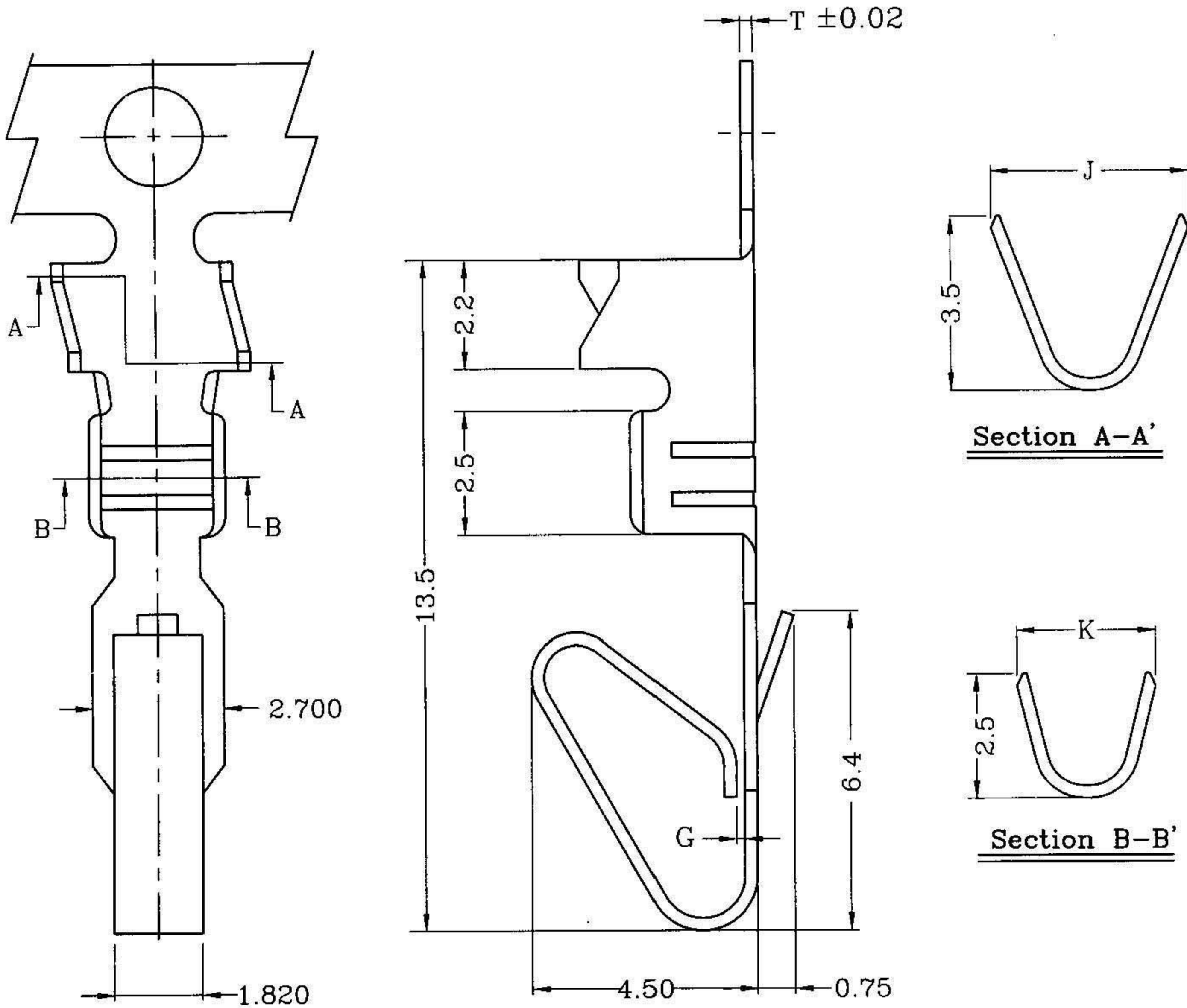

Specifications & Ordering Information:

Part No	Dimension(mm)				Wire Range	Insulation O.D.	Material	Finish	Qty/reel
	T	J	K	G					
C	0.25	4.1	2.5	0.30(max)	AWG #18~#22	2.80mm(max)	Brass (Phosphor-Bronze)	Tin-plated	6,000 PCS
D	0.30	3.75 ±0.25	2.5	0.30(max)	AWG #18~#22	2.80mm(max)	Brass (Phosphor-Bronze)	Tin-plated	6,000 PCS



REV.	ECN NO.	UNIT	TOLERANCE	PROJECTION	DRAWING	CHECK	APPROVAL
E		mm	*** ±0.08		汪霞 9/20'06		
			** ±0.15				
F			* ±0.25				